

Vehicular Network and Street Types

LSU South Campus. Master Plan and Design Codes section D Thoroughfare Standards



Refer to page 45 for further explanation of the Thoroughfare Standards.

LEGEND

- AST-48
- BLVD-138A
- BLVD-138B
- BLVD-150
- BLVD-VA
- BLVD-VB
- BP-14
- GSRI-100
- CS-67
- PS-20
- R-41
- ST-48
- ST-64
- ST-71

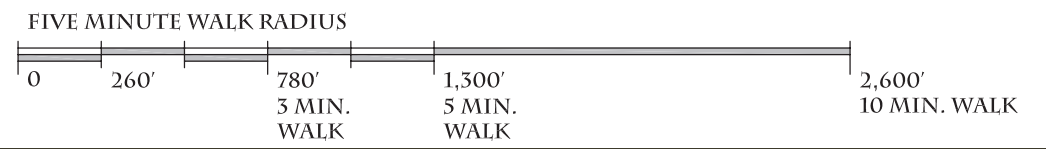
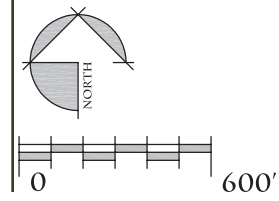



Vehicular Network and Street Types A

Key Plan



Refer to page 45 for further explanation of the Thoroughfare Standards.

LEGEND

- AST-48
- BLVD-138A
- BLVD-138B
- BLVD-150
- BLVD-VA
- BLVD-VB
- BP-14
- GSRI-100
- CS-67
- PS-20
- R-41
- ST-48
- ST-64
- ST-71

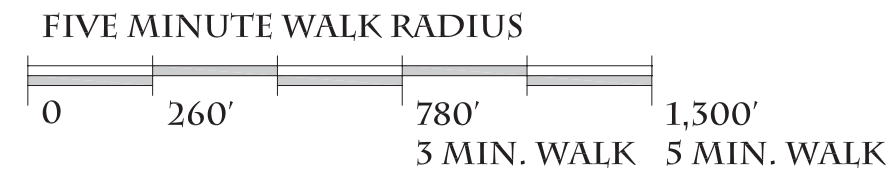
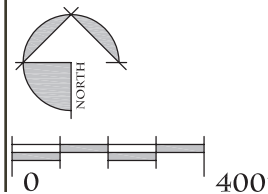

Thoroughfare Standards

D section

LSU South Campus. Master Plan and Design Codes





Vehicular Network and Street Types A

Key Plan



Refer to page 45 for further explanation of the Thoroughfare Standards.

LEGEND

- AST-48
- BLVD-138A
- BLVD-138B
- BLVD-150
- BLVD-VA
- BLVD-VB
- BP-14
- GSRI-100
- CS-67
- PS-20
- R-41
- ST-48
- ST-64
- ST-71

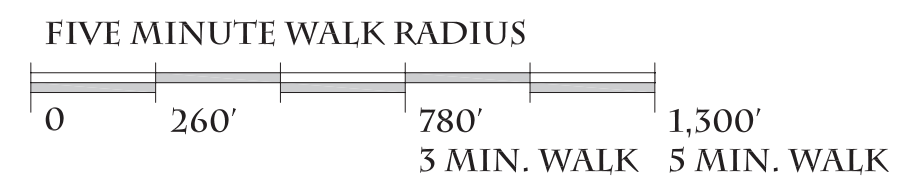
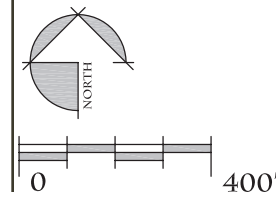

LSU South Campus. Master Plan and Design Codes section D Thoroughfare Standards

D Vehicular Network and Street Types A



On-Street Parking

LSU South Campus. Master Plan and Design Codes section D Thoroughfare Standards



Refer to page 45 for further explanation of the Thoroughfare Standards.

LEGEND

FORMAL PARKING

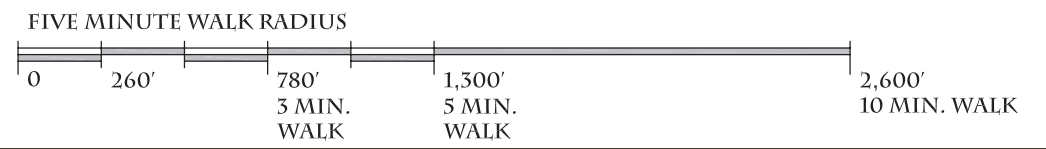
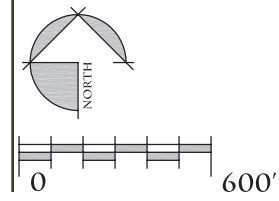

D On-Street Parking





On-Street Parking A

Key Plan



Refer to page 45 for further explanation of the Thoroughfare Standards.

LEGEND

 FORMAL PARKING

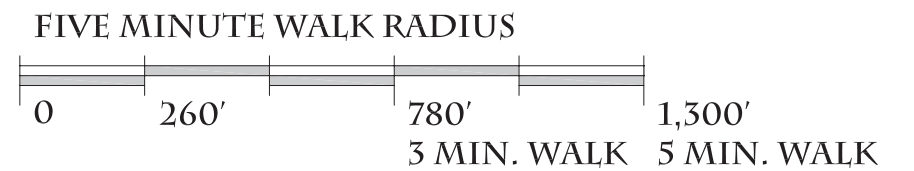
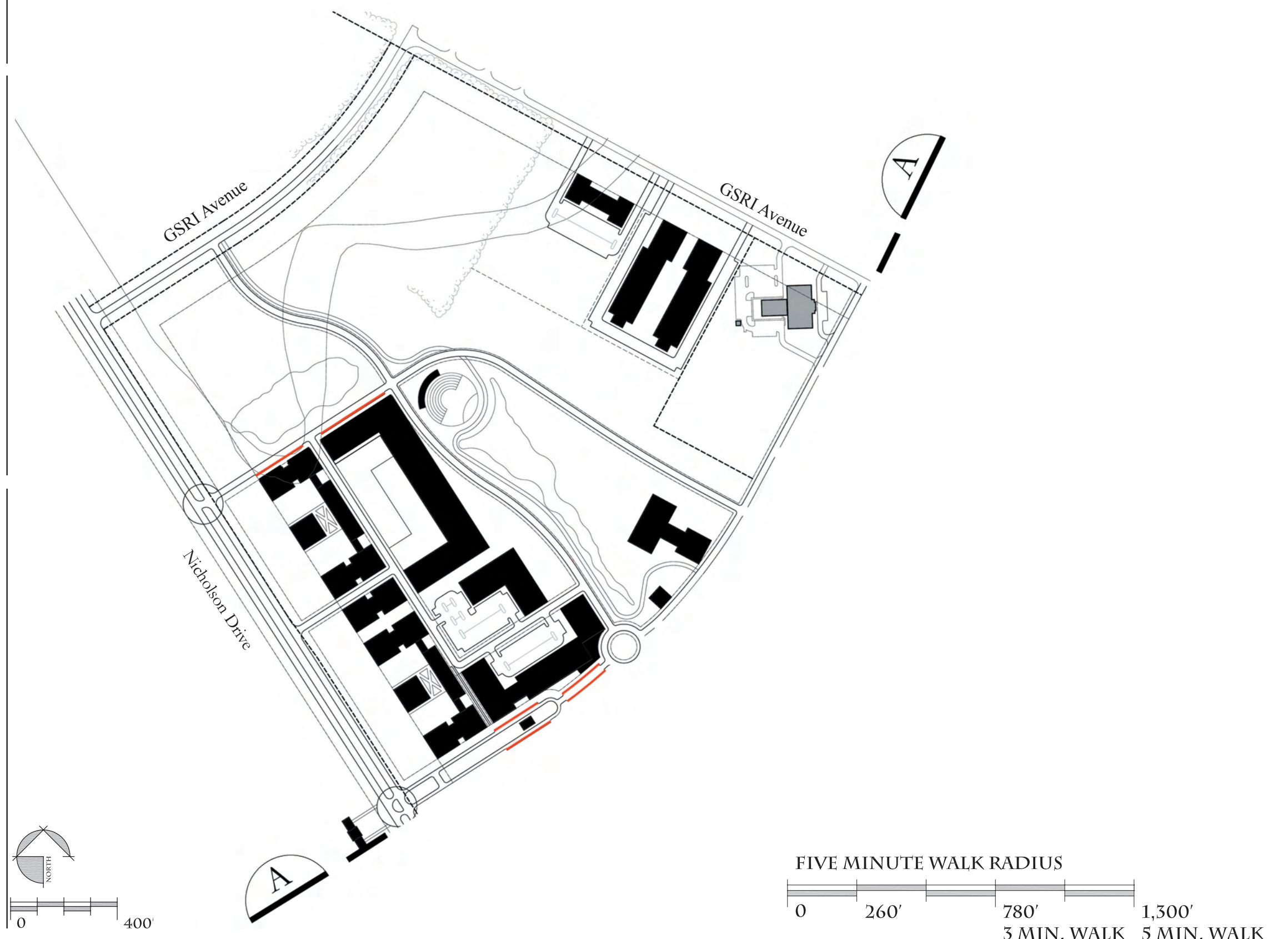
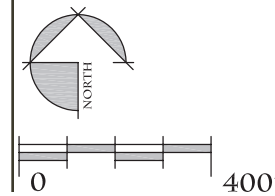

LSU South Campus. Master Plan and Design Codes section D Thoroughfare Standards





On-Street Parking B

Key Plan



Refer to page 45 for further explanation of the Thoroughfare Standards.

LEGEND

— FORMAL PARKING

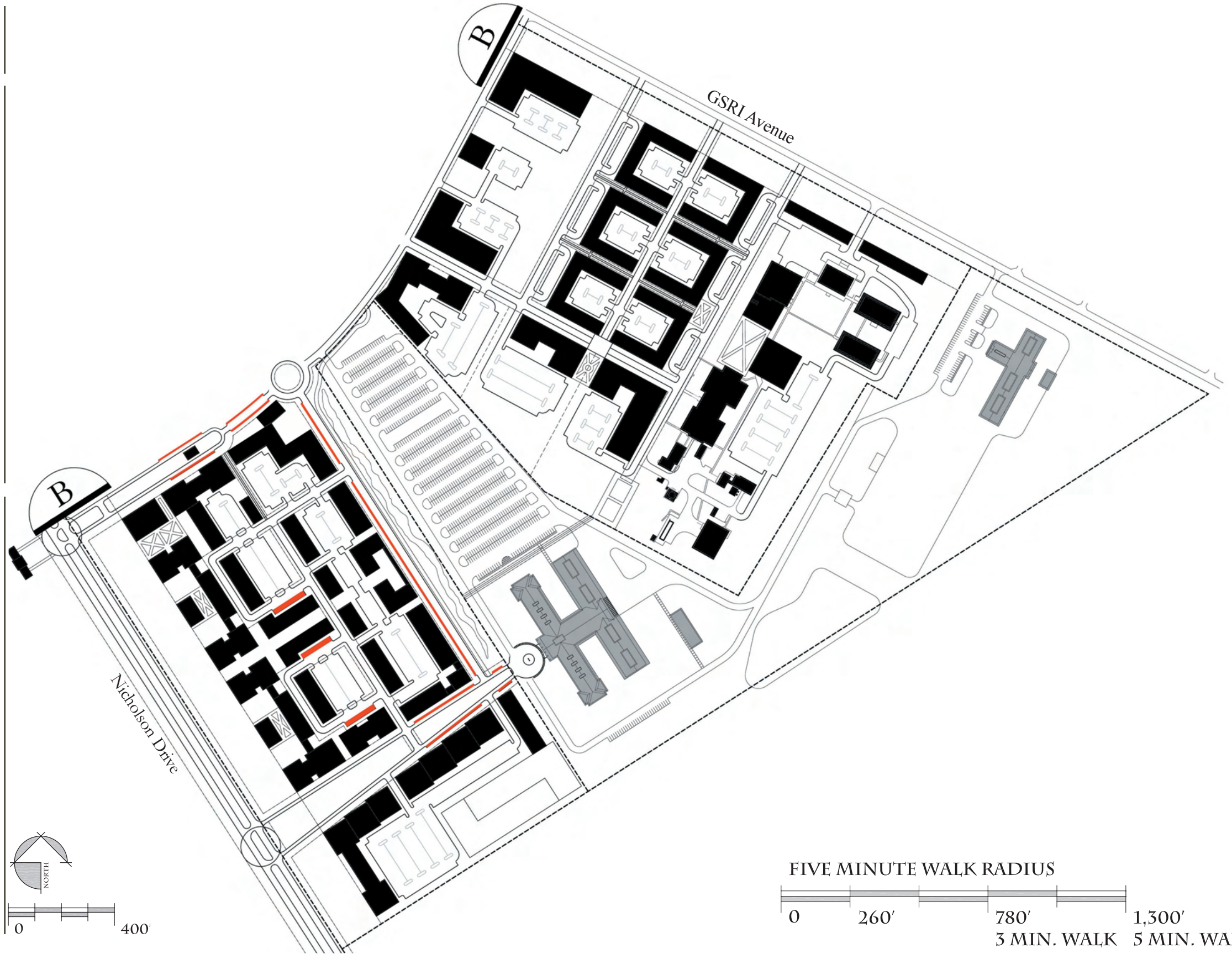
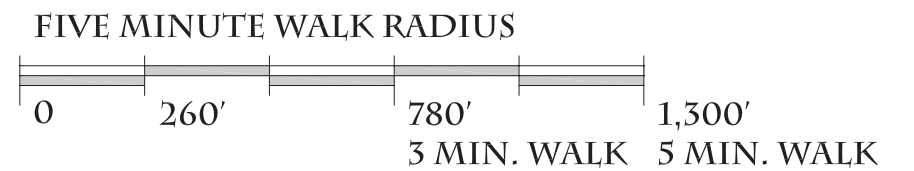
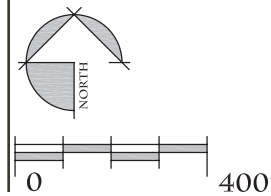

LSU South Campus. Master Plan and Design Codes section D Thoroughfare Standards





Existing Nicholson Drive

(150)
(11/11)

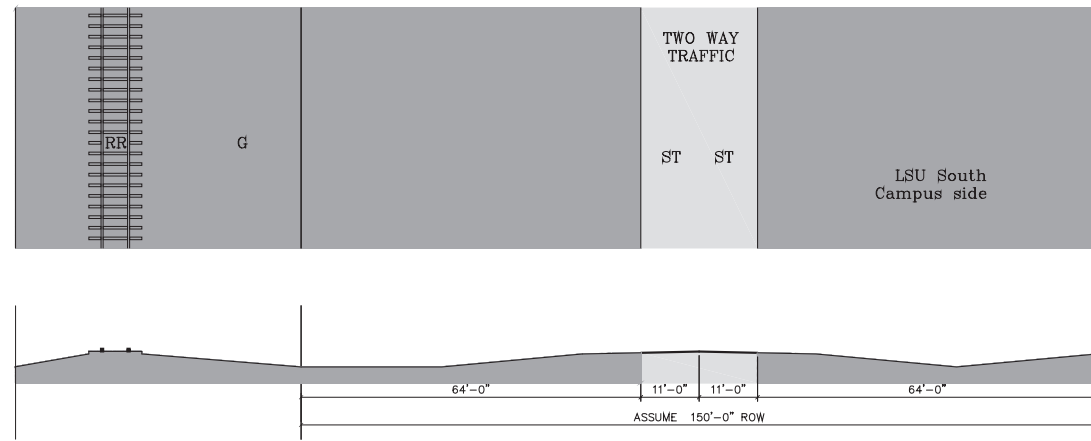

EXISTING NICHOLSON DRIVE-150

DESIGN SPEED:	55 MPH	PEDESTRIAN CROSSING TIME:	6 SEC.
PAVEMENT WIDTH:	22'-0"	DRAINAGE:	DITCH
ROW WIDTH:	150'-0"	AVERAGE DAILY TRAFFIC:	<20000
MAX. CURB RADIUS:	25'-0"	CURB TYPE:	NONE
PARKING:	NONE		

Proposal at Nicholson Drive

(BLVD-150)
(2/12/12/12/12/2)

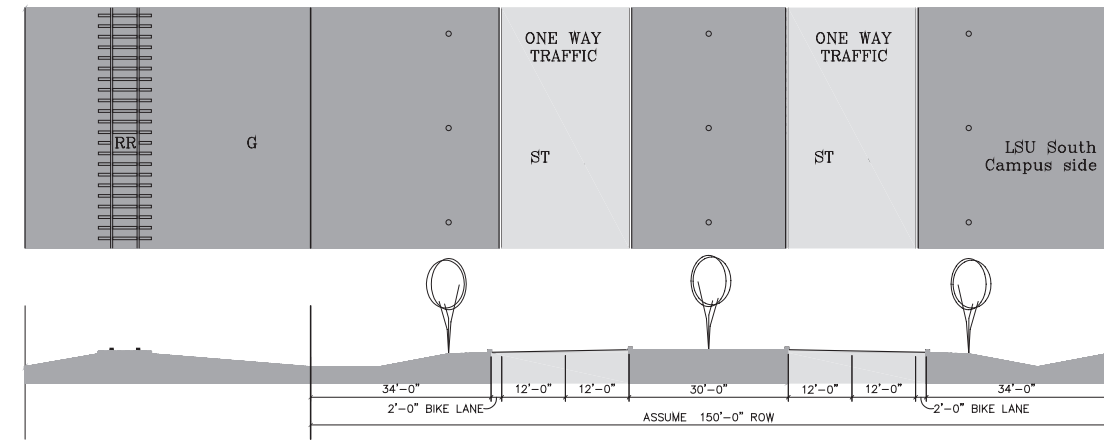

BLVD-150

DESIGN SPEED:	35 MPH	PEDESTRIAN CROSSING TIME:	___ SEC.
PAVEMENT WIDTH:	26'-0" E.A.	DRAINAGE:	DITCH
ROW WIDTH:	150'-0"	AVERAGE DAILY TRAFFIC:	<20000
MAX. CURB RADIUS:	25'-0"	CURB TYPE:	BARRIER
PARKING:	NONE		

Boulevard

(BLVD-138A)
(14/14)

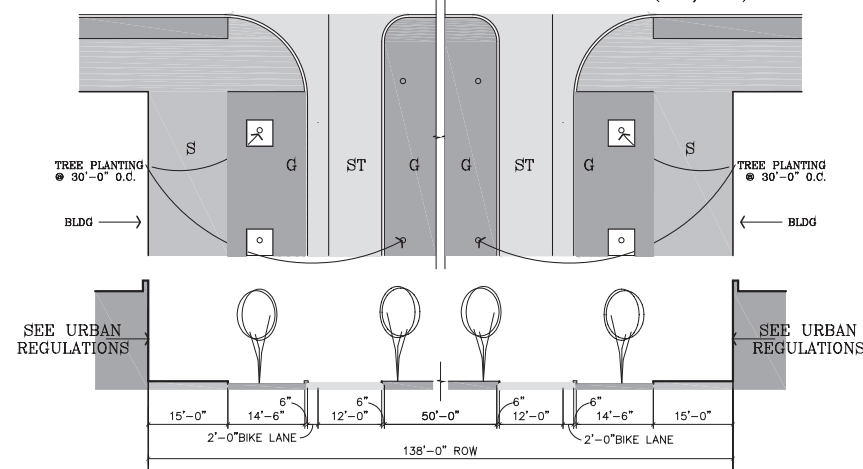

BLVD-138A

DESIGN SPEED:	25 MPH	PEDESTRIAN CROSSING TIME:	14 SEC.
PAVEMENT WIDTH:	14'-0" EA.	DRAINAGE:	CURB
ROW WIDTH:	138'-0"	AVERAGE DAILY TRAFFIC:	<2500
MAX. CURB RADIUS:	10'-0"	CURB TYPE:	BARRIER
MAX. CURB RADIUS @ INTERIOR STREETS:	10'-0"	PARKING:	NONE
MAX. CURB RADIUS @ STATE HWY.(NICHOLSON):	PER STATE STANDARDS		

Boulevard

(BLVD-138B)
(8/14/14/8)

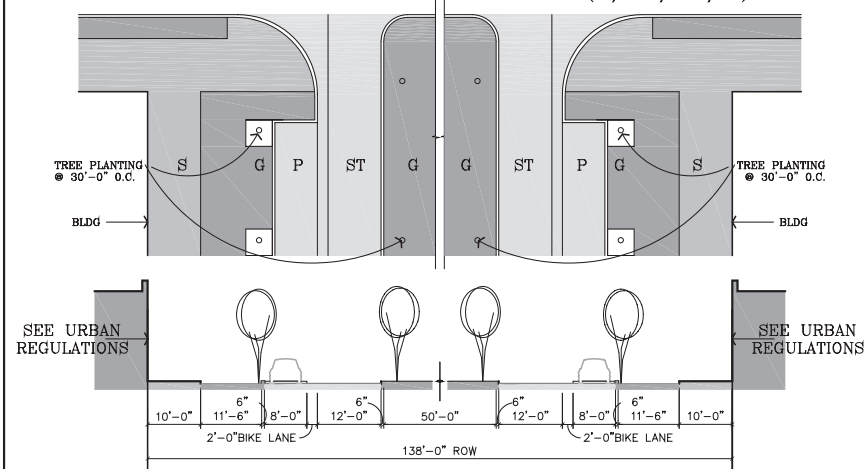

BLVD-138B

DESIGN SPEED:	25 MPH	PEDESTRIAN CROSSING TIME:	14 SEC.
PAVEMENT WIDTH:	22'-0" EA.	DRAINAGE:	CURB
ROW WIDTH:	138'-0"	AVERAGE DAILY TRAFFIC:	<2500
MAX. CURB RADIUS:	10'-0"	CURB TYPE:	BARRIER
PARKING:	FORMAL (PARALLEL)		





Boulevard (BLVD-VA)
(12/12)

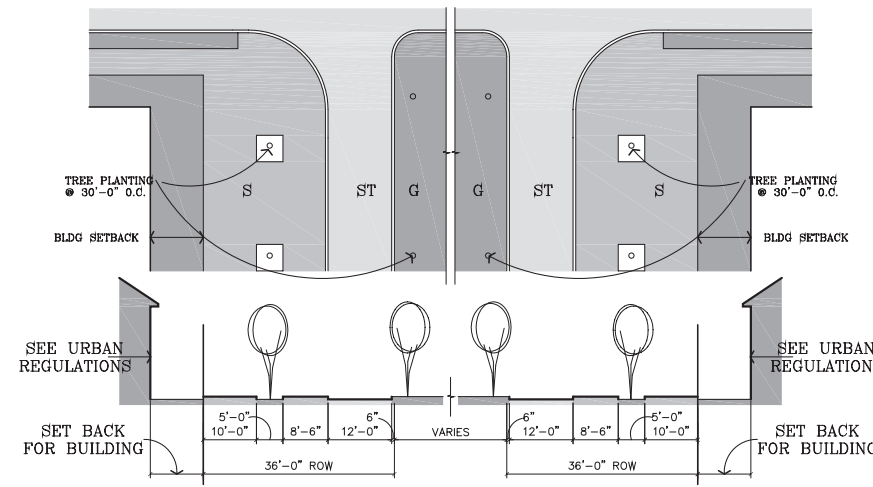

BLVD-VA

DESIGN SPEED:	25 MPH	PEDESTRIAN CROSSING TIME:	14 SEC.
PAVEMENT WIDTH:	12'-0" EA.	DRAINAGE:	CURB
ROW WIDTH:	36'-0" EA.	AVERAGE DAILY TRAFFIC:	<2500
MAX. CURB RADIUS:		CURB TYPE:	BARRIER
◎ INTERIOR STREETS:	10'-0"	CURB TYPE @ BIOSWALE:	BARRIER PERFORATED
MAX. CURB RADIUS:		PARKING:	NONE
◎ STATE HWY.(NICHOLSON):	PER STATE STANDARDS		

Boulevard (BLVD-VB)
(8/12/12/8)

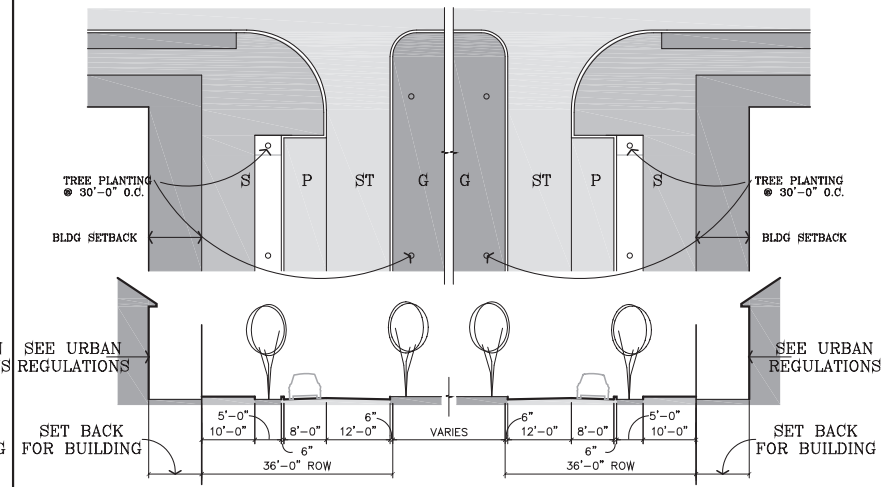

BLVD-VB

DESIGN SPEED:	25 MPH	PEDESTRIAN CROSSING TIME:	14 SEC.
PAVEMENT WIDTH:	20'-0" EA.	DRAINAGE:	CURB
ROW WIDTH:	36'-0" EA.	AVERAGE DAILY TRAFFIC:	<2500
MAX. CURB RADIUS:	10'-0"	CURB TYPE:	BARRIER
PARKING:	FORMAL (PARALLEL)	CURB TYPE @ BIOSWALE:	BARRIER PERFORATED

Commercial Street (CS-67)
(8/12/12/8)

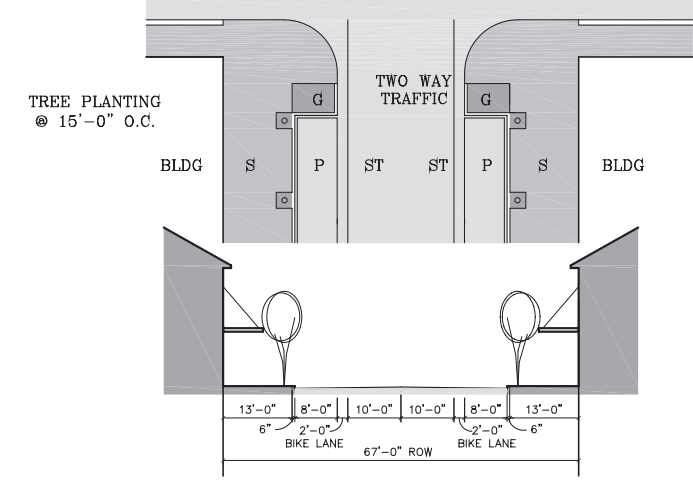

CS-67

DESIGN SPEED:	20 MPH	PEDESTRIAN CROSSING TIME:	10 SEC.
PAVEMENT WIDTH:	40'-0"	DRAINAGE:	CURB
ROW WIDTH:	67'-0"	AVERAGE DAILY TRAFFIC:	<1000
MAX. CURB RADIUS:	10'-0"	CURB TYPE:	BARRIER
PARKING:	FORMAL (PARALLEL)		

Arcade Street (AST-48)
(8/12/12)

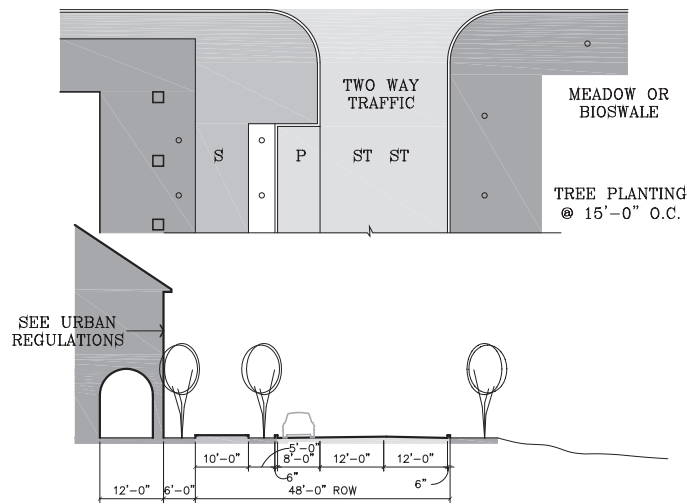

AST-48

DESIGN SPEED:	20 MPH	PEDESTRIAN CROSSING TIME:	5 SEC.
PAVEMENT WIDTH:	32'-0"	DRAINAGE:	SURFACE GUTTER
ROW WIDTH:	48'-0"	CURB TYPE:	BARRIER
MAX. CURB RADIUS:		PARKING:	FORMAL (PARALLEL)
◎ INTERIOR STREETS:	10'-0"	CURB TYPE @ BIOSWALE:	BARRIER PERFORATED
MAX. CURB RADIUS @ STATE HWY.(NICHOLSON):	PER STATE STANDARDS		

Road (R-41)
(12/12)

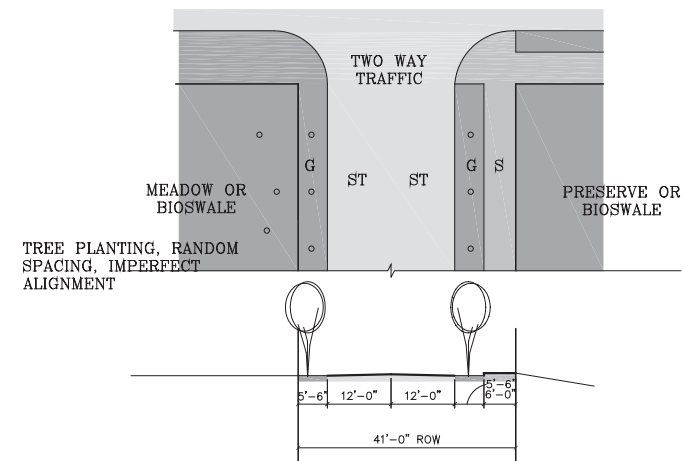

R-41

DESIGN SPEED:	20 MPH	PEDESTRIAN CROSSING TIME:	6 SEC.
PAVEMENT WIDTH:	24'-0"	DRAINAGE:	CURB
ROW WIDTH:	41'-0"	AVERAGE DAILY TRAFFIC:	<1000
MAX. CURB RADIUS:	10'-0"	CURB TYPE:	FLAT
PARKING:	NONE		

Street (ST-64)
(12/12)

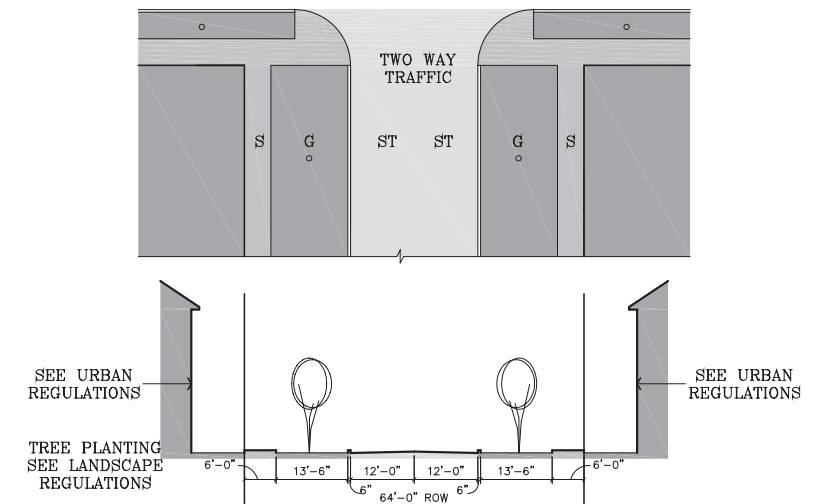

ST-64

DESIGN SPEED:	20 MPH	PEDESTRIAN XING TIME:	7 SEC.
PAVEMENT WIDTH:	24'-0"	DRAINAGE:	SURFACE GUTTER
ROW WIDTH:	64'-0"	CURB TYPE:	BARRIER
MAX. CURB RADIUS:	10'-0"	PARKING:	NONE





Street (ST-71)
(12/12/23)

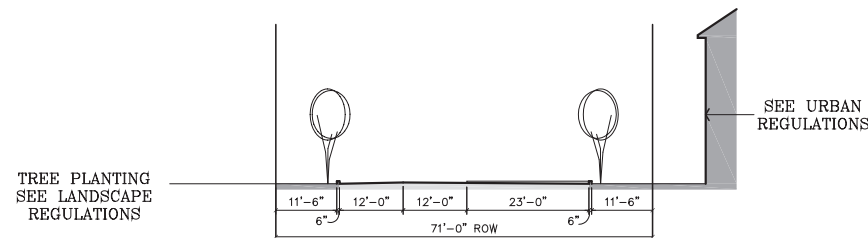
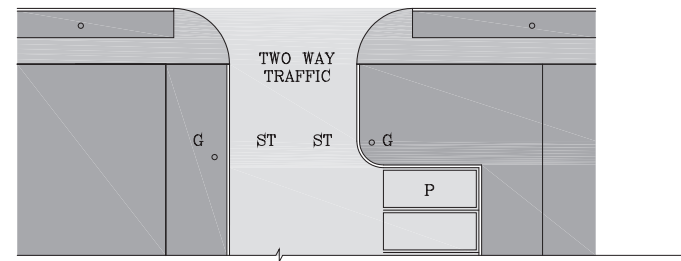

ST-48

DESIGN SPEED:	20 MPH	PEDESTRIAN XING TIME:	7 SEC.
PAVEMENT WIDTH:	47'-0"	DRAINAGE:	SURFACE GUTTER
ROW WIDTH:	71'-0"	CURB TYPE:	BARRIER
MAX. CURB RADIUS:	10'-0"	PARKING:	FORMAL(DIVE-IN)

Street (ST-48)
(14/14)

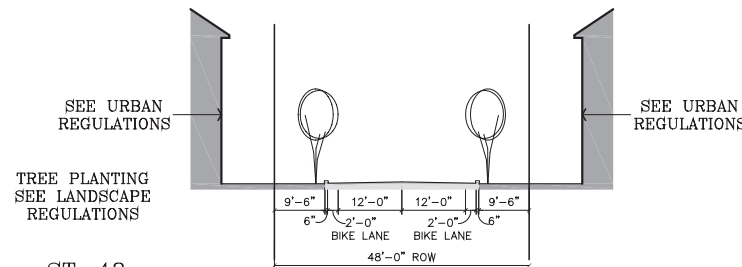
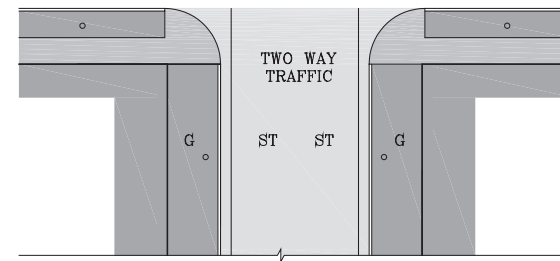

ST-48

DESIGN SPEED:	20 MPH	PEDESTRIAN XING TIME:	7 SEC.
PAVEMENT WIDTH:	28'-0"	DRAINAGE:	SURFACE GUTTER
ROW WIDTH:	48'-0"	CURB TYPE:	BARRIER
MAX. CURB RADIUS:	10'-0"	PARKING:	NONE

GSRI (GSRI-100)
(12/12)

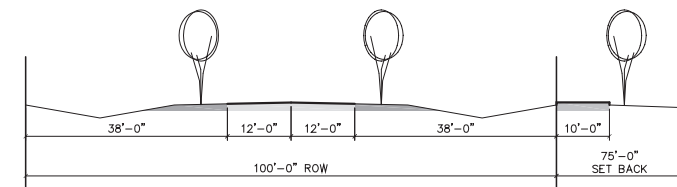
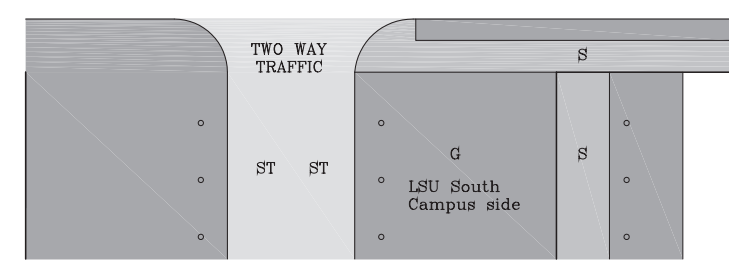

GSRI-100

DESIGN SPEED:	35 MPH	PEDESTRIAN CROSSING TIME:	6 SEC.
PAVEMENT WIDTH:	24'-0"	DRAINAGE:	CURB
ROW WIDTH:	100'-0"	AVERAGE DAILY TRAFFIC:	<2500
MAX. CURB RADIUS:	10'-0"	CURB TYPE:	FLAT
PARKING:	NONE		

Bike Path (BP-10&14)
(10 & 14)

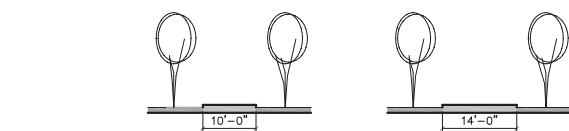
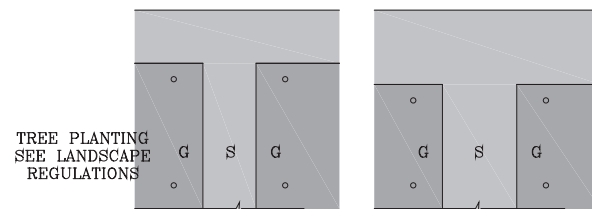

BP-10 & 14

DESIGN SPEED:	N/A	PEDESTRIAN CROSSING TIME:	N/A
MIN. CENTERLINE RADIUS:	N/A	DRAINAGE:	N/A
PAVEMENT WIDTH:	N/A	AVERAGE DAILY TRAFFIC:	N/A
ROW WIDTH:	N/A		
MAX. CURB RADIUS:	N/A		

Passage (PS-20)

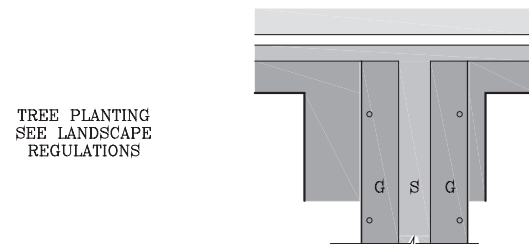

TREE PLANTING
SEE LANDSCAPE
REGULATIONS

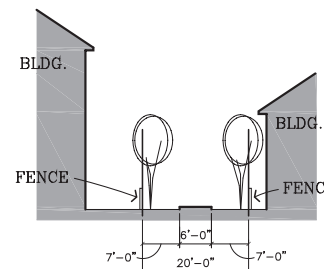

PS-20

DESIGN SPEED:	N/A	PEDESTRIAN CROSSING TIME:	N/A
MIN. CENTERLINE RADIUS:	N/A	DRAINAGE:	N/A
PAVEMENT WIDTH:	N/A	AVERAGE DAILY TRAFFIC:	N/A
ROW WIDTH:	N/A		
MAX. CURB RADIUS:	N/A		





Street Paving Materials – Option A

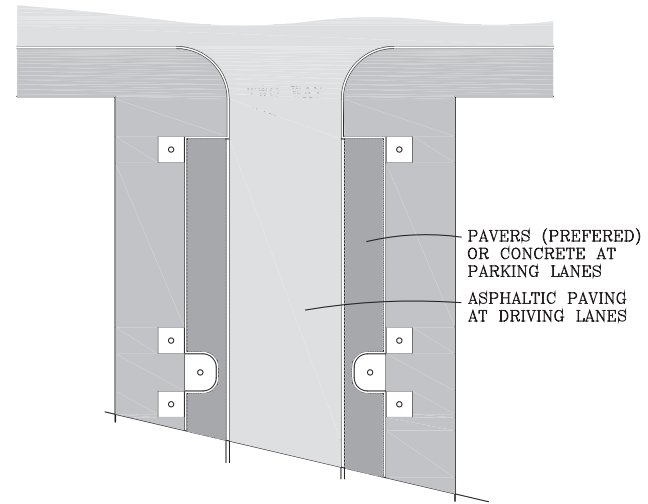

Street Paving Materials – Option B

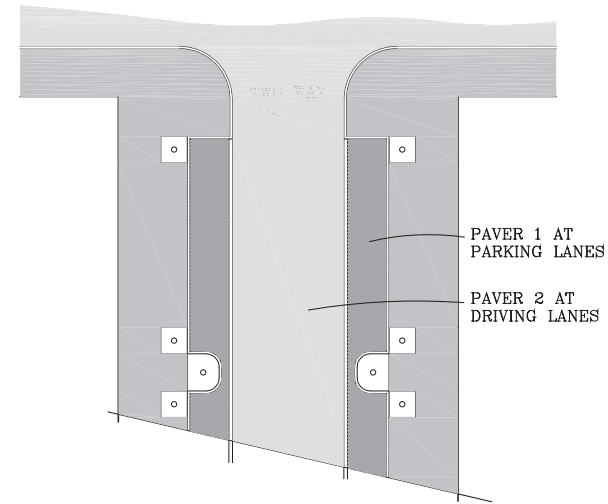

Curb Types

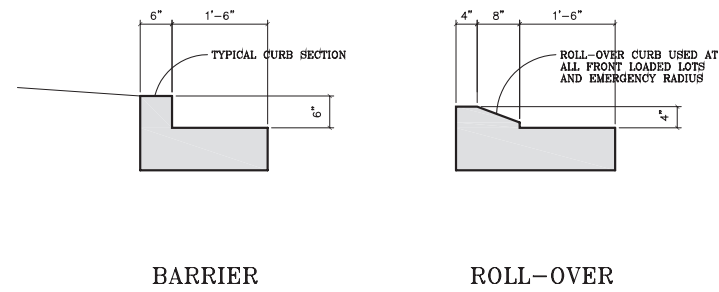

Bulb-outs

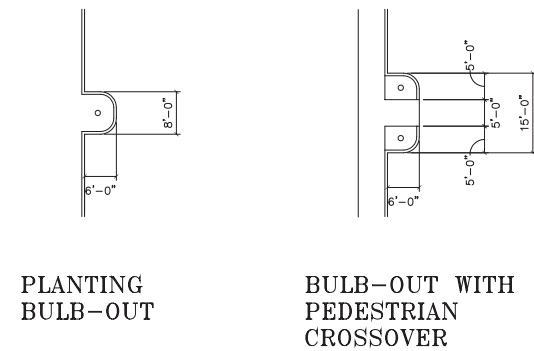



Visibility Triangle

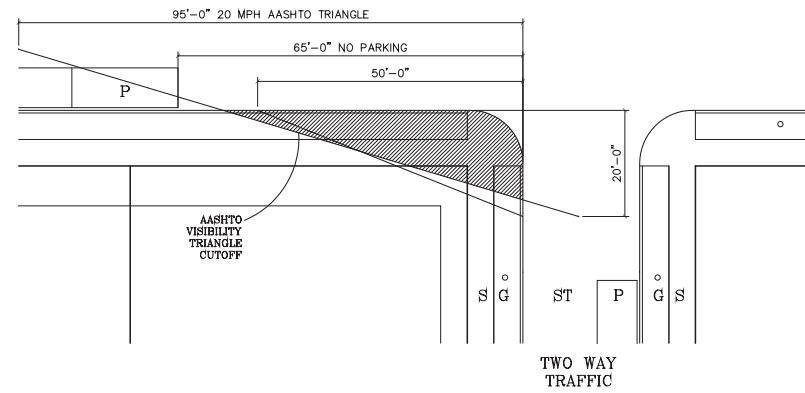

Emergency Radius

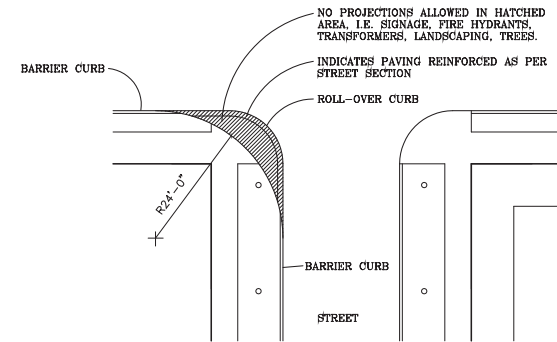

Visibility Triangle

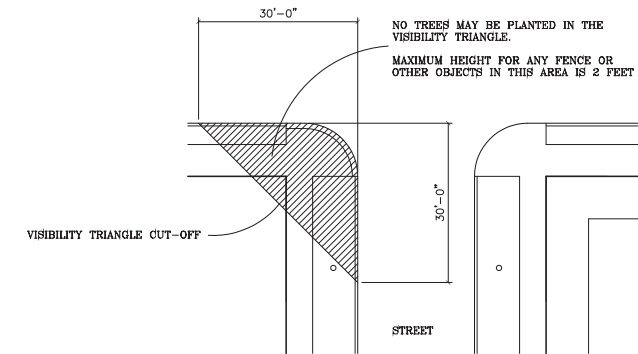



Pedestrian Network

Thoroughfare Standards

D

LSU South Campus. Master Plan and Design Codes section



LEGEND

- Formal
- Informal (Path)

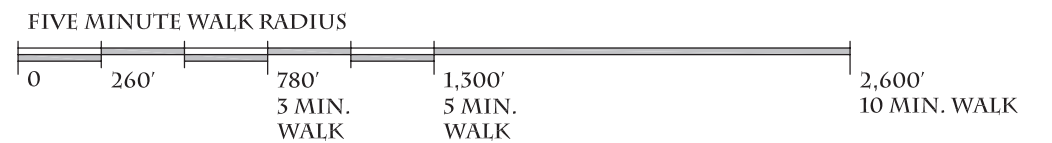
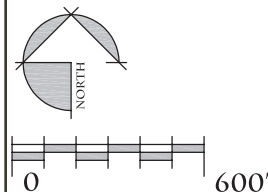

ARCHITECTS
SOUTHWEST

Louisiana State University
South Campus Master Plan

Master Plan and Design Codes

© COPYRIGHT 2008 10.20.2008

Baton Rouge, Louisiana





Pedestrian Network A

Key Plan



Thoroughfare Standards

D

section

LSU South Campus. Master Plan and Design Codes

LEGEND

- Formal
- Informal (Path)

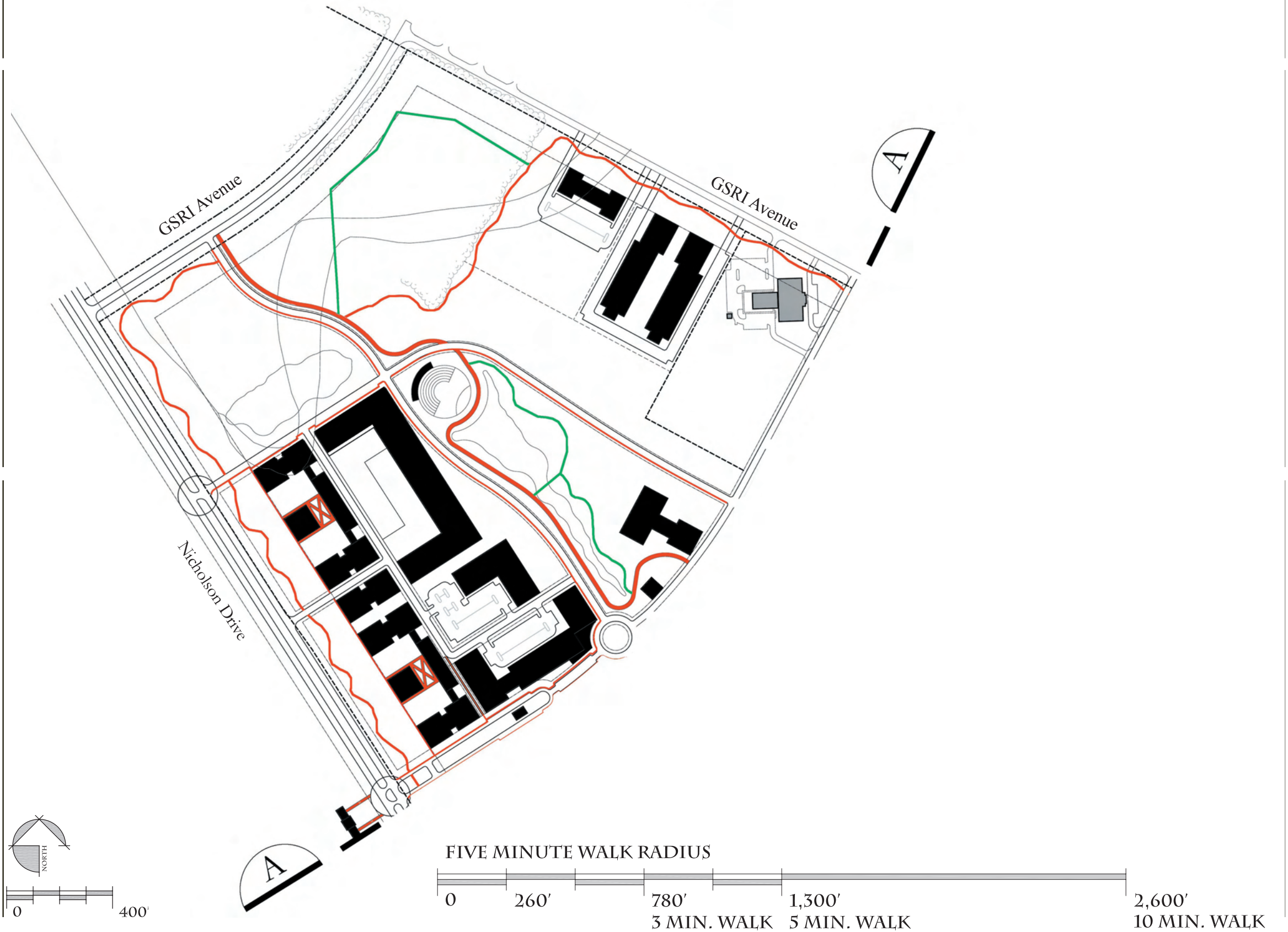
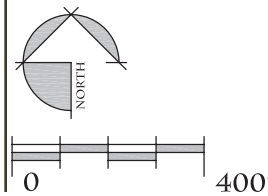

ARCHITECTS
SOUTHWEST

Louisiana State University

South Campus Master Plan

Master Plan and Design Codes

© COPYRIGHT 2008 10.20.2008

Baton Rouge, Louisiana





Pedestrian Network B

Key Plan



LEGEND

- Formal
- Informal (Path)

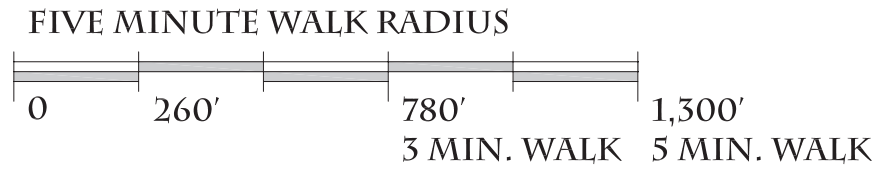
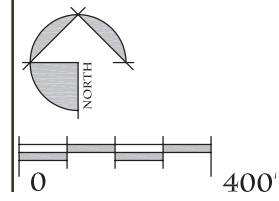

LSU South Campus. Master Plan and Design Codes section D Thoroughfare Standards



Five Minute Walk

LSU South Campus. Master Plan and Design Codes section D Thoroughfare Standards



LEGEND

FIVE MINUTE WALK

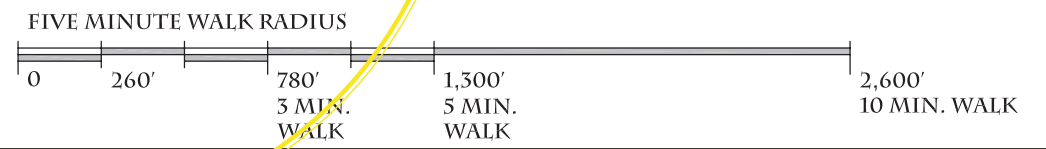
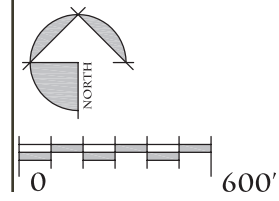

ARCHITECTS
SOUTHWEST
Louisiana State University
South Campus Master Plan

© COPYRIGHT 2008 10.20.2008

Baton Rouge, Louisiana

Master Plan and Design Codes

